

Population Structure

Subdivided (fragmented) populations

Subdivided populations

- Large natural population with gene flow across the population is fragmented into a number of smaller populations.
 - Habitat destruction; creation of man-made barriers; alteration of landscapes.
- What are the consequences?

Subdivided populations

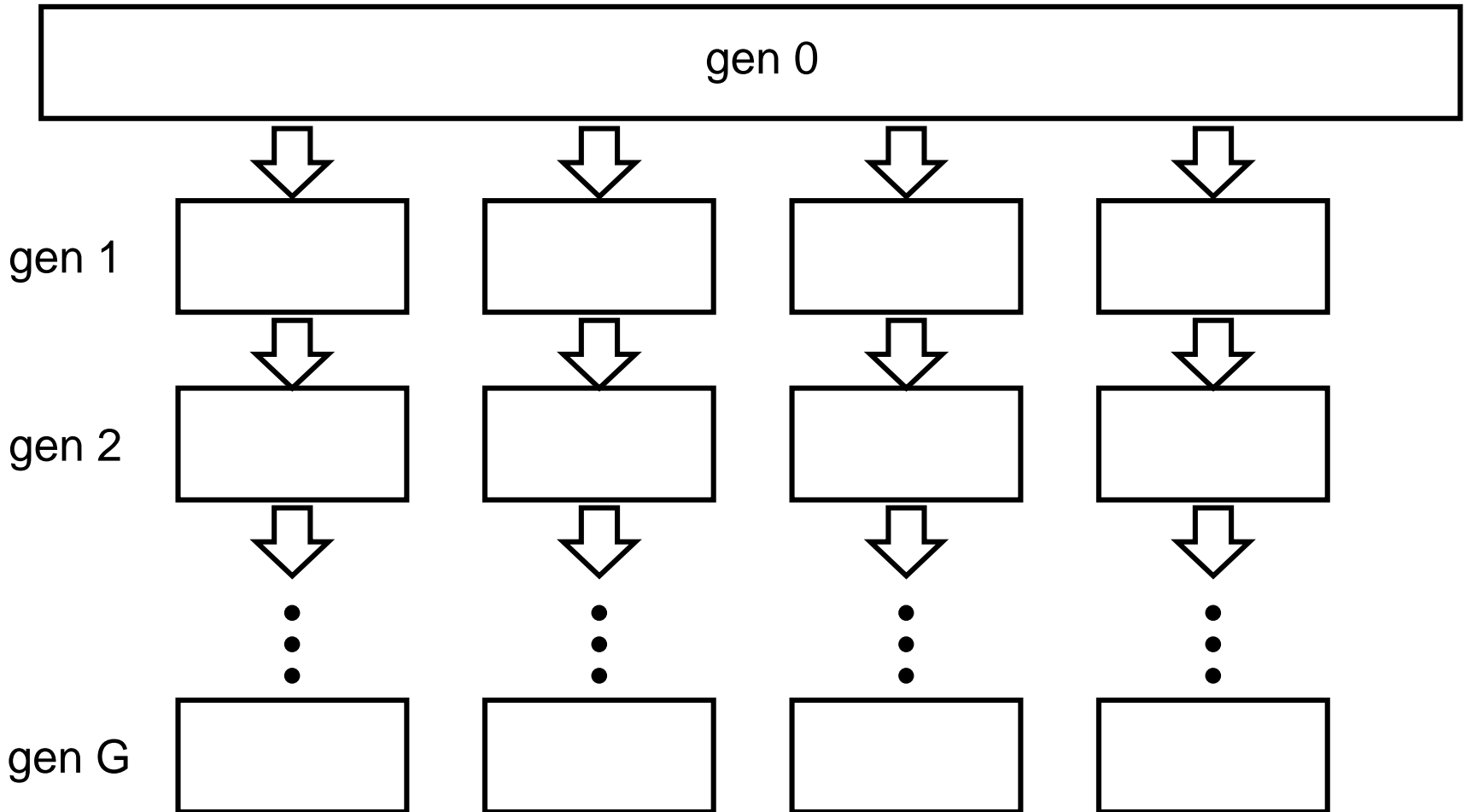

Subdivided populations

- The smaller subpopulations are more susceptible to the forces of drift ...
 - drift acts more quickly within smaller subpopulations than it did in the larger original population.
- Variation will be lost in subpopulations.
- Sub-populations will start to diverge.

Exercise

- Can we measure the amount of divergence between subpopulations?
- Run the inbreeding tool a few (say 5-6) times.
- Consider each simulation to be one subpopulation from a historically larger, now fragmented population.

Exercise

- Extreme case: no migration between subpopulations.
- Assume random mating within subpopulations
 - can relax this assumption later.
- Consider the conglomeration of all the subpopulations to be the total population.

- Consider the conglomeration of all the subpopulations to be the total population.

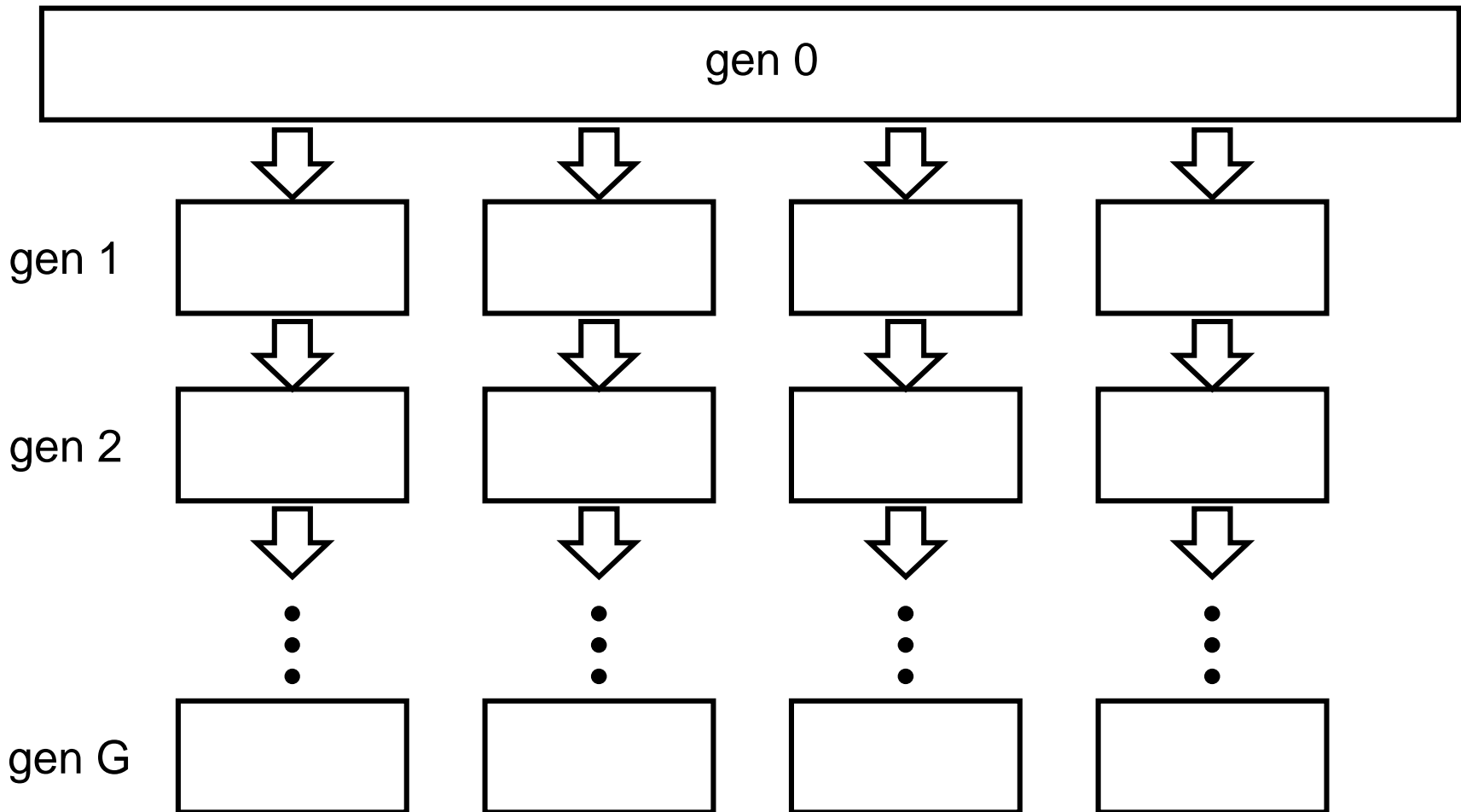

- Consider the conglomeration of all the subpopulations to be the total population.

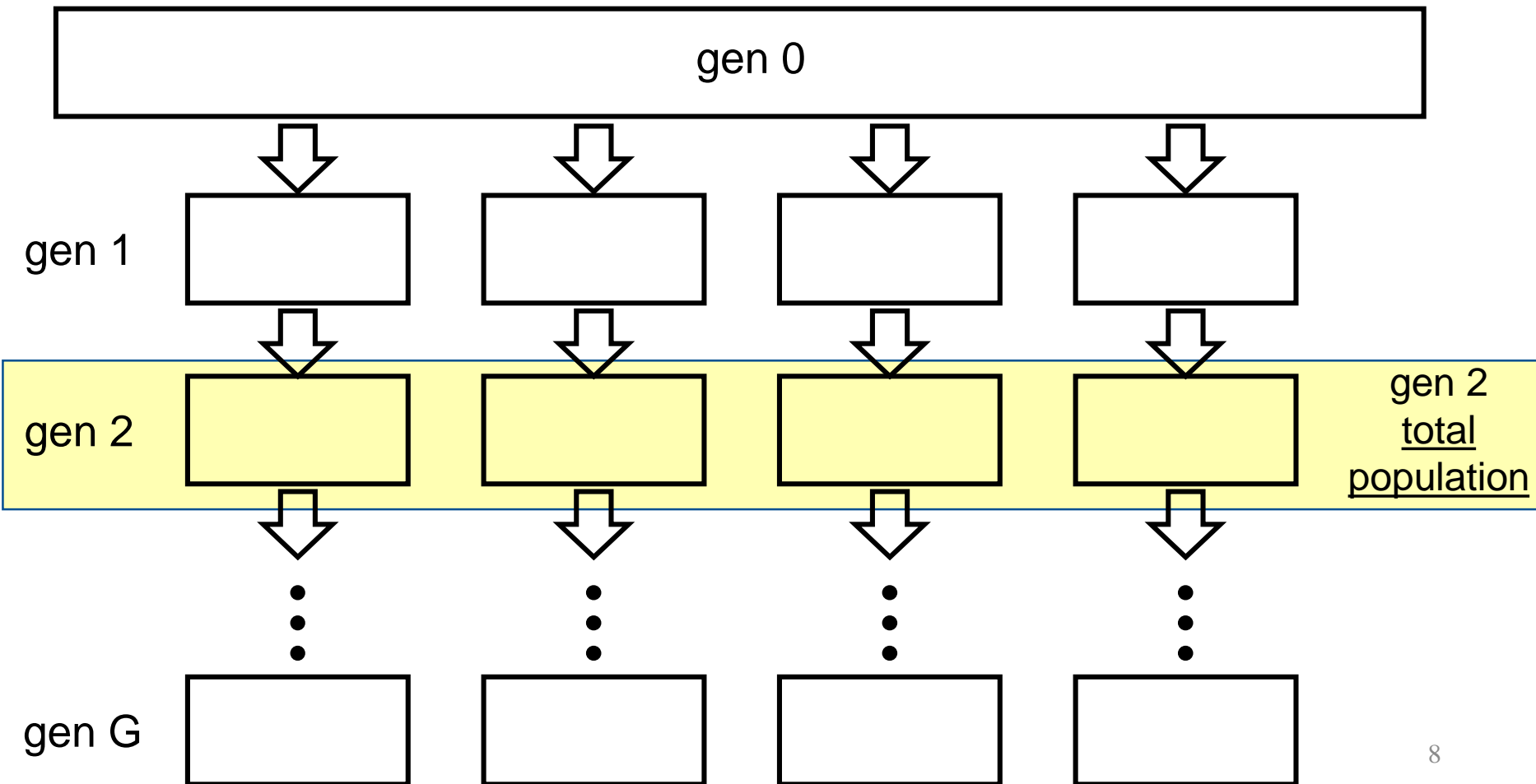

- Consider the conglomeration of all the subpopulations to be the total population.
- These individuals don't cross-breed: you simply collect individuals and call the collection the "total population."

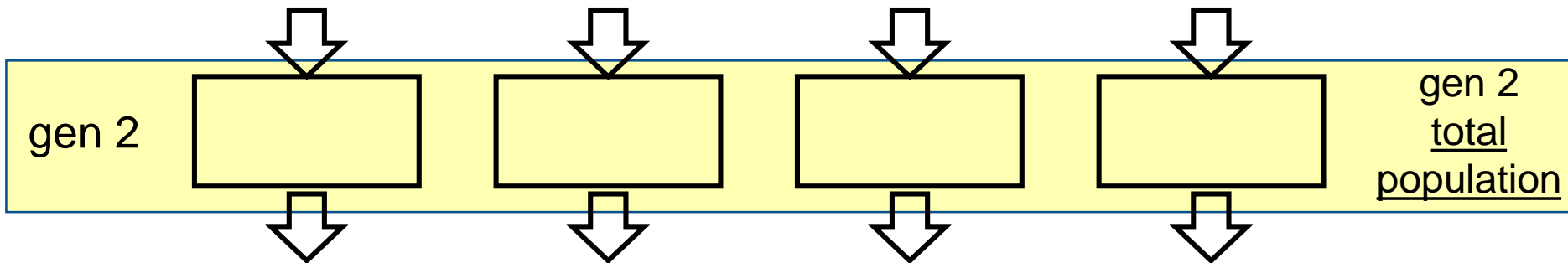

(Each one on its own is a subpopulation)

Exercise

- Run the inbreeding tool a few (say 5-6) times.
- For each run, pay attention to the amount of genetic variation you see within subpopulations in the first few generations versus the last few generations:
 - how many different alleles there are and the proportion of heterozygous genotypes.

Exercise

- For the conglomerate total population, in which generations (first few or final few) does substantial genetic variation exist within subpopulations?
- For which generations does genetic variation exist mainly across the total population (rather than appearing within subpopulations)?

Wright's F statistics

- F_{ST} is the most commonly used.
- Measure of divergence between subpopulations.
 - Expected to be between 0 and 1.
 - Larger values indicate higher divergence of subpopulations.
- When subpopulations are highly diverged, most of the genetic variation exists at the level of the total population
 - not within subpopulations.

Interpreting F_{ST}

- Measure of variances of allele frequencies within subpopulations ...

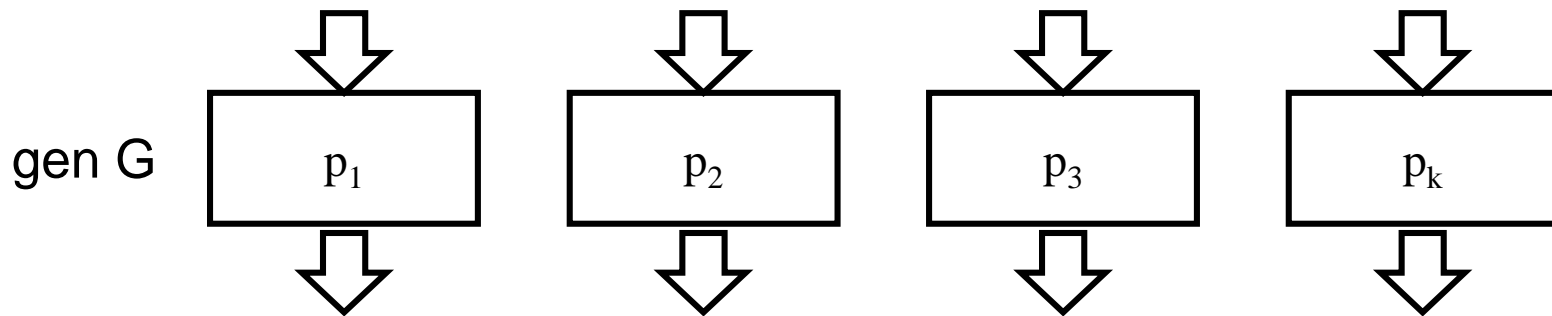

- For k subpopulations, have k allele frequencies (for a given allele), p_1, \dots, p_k .
- If the allele frequencies are very different between subpopulations, F_{ST} is large.
 - populations have diverged substantially.

Interpreting F_{ST}

- Measure of variances of allele frequencies within subpopulations ...

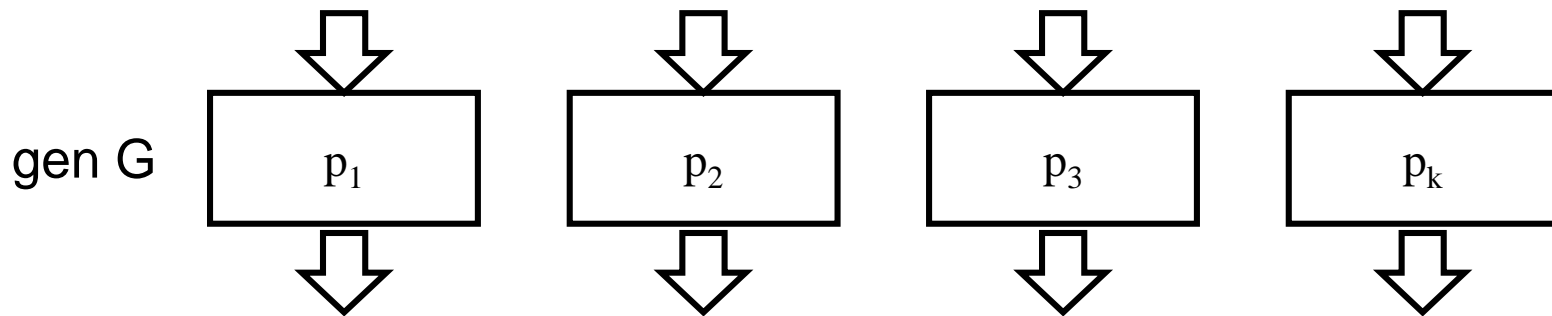

- For k subpopulations, have k allele frequencies (for a given allele), p_1, \dots, p_k .
- If the allele frequencies are very similar between subpopulations, F_{ST} is small.
 - populations have not diverged substantially.

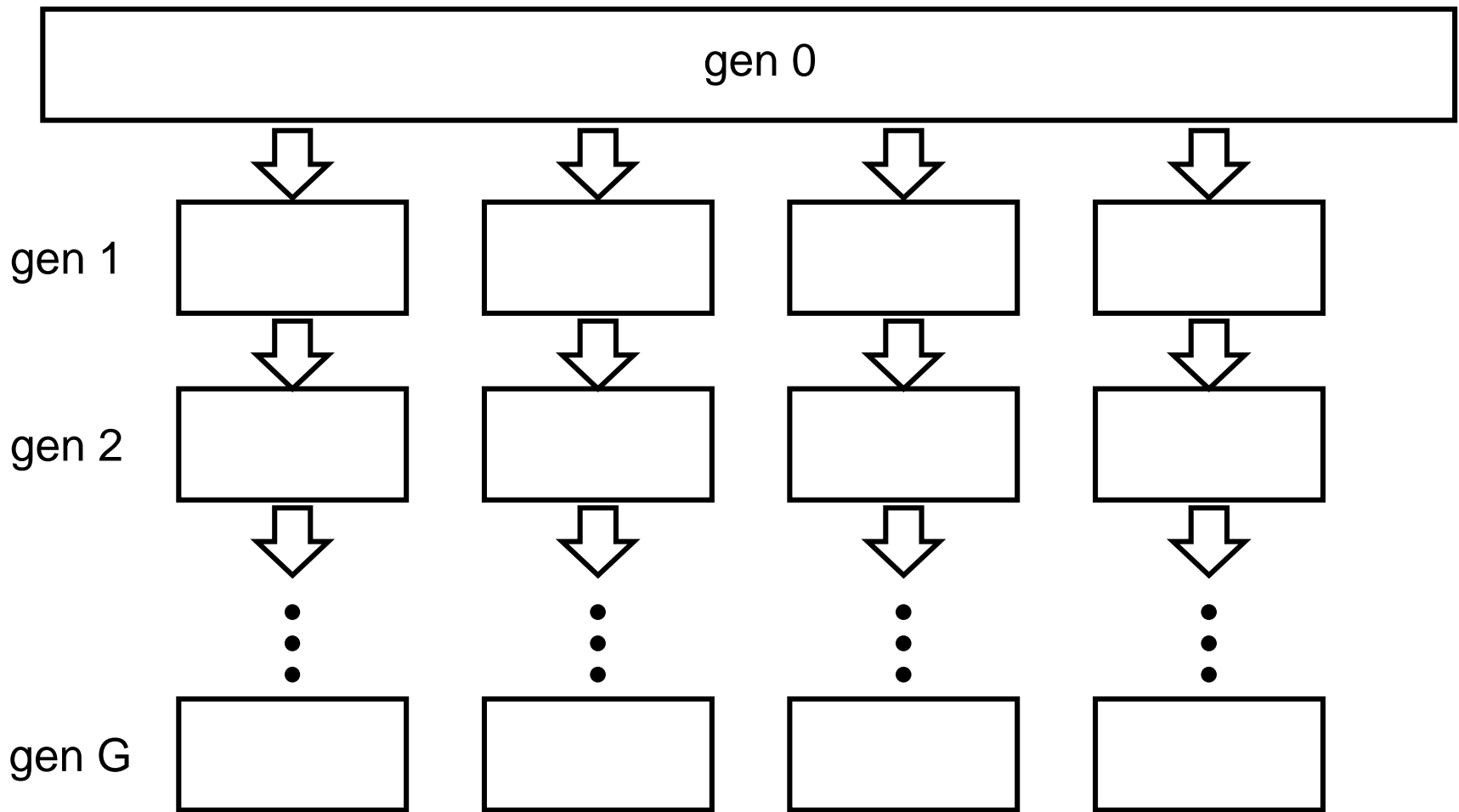

Early in the process (before much time has passed after fragmentation), the subpopulations' genetic composition will be similar to each other. Allele frequencies will be similar (variance will be low).

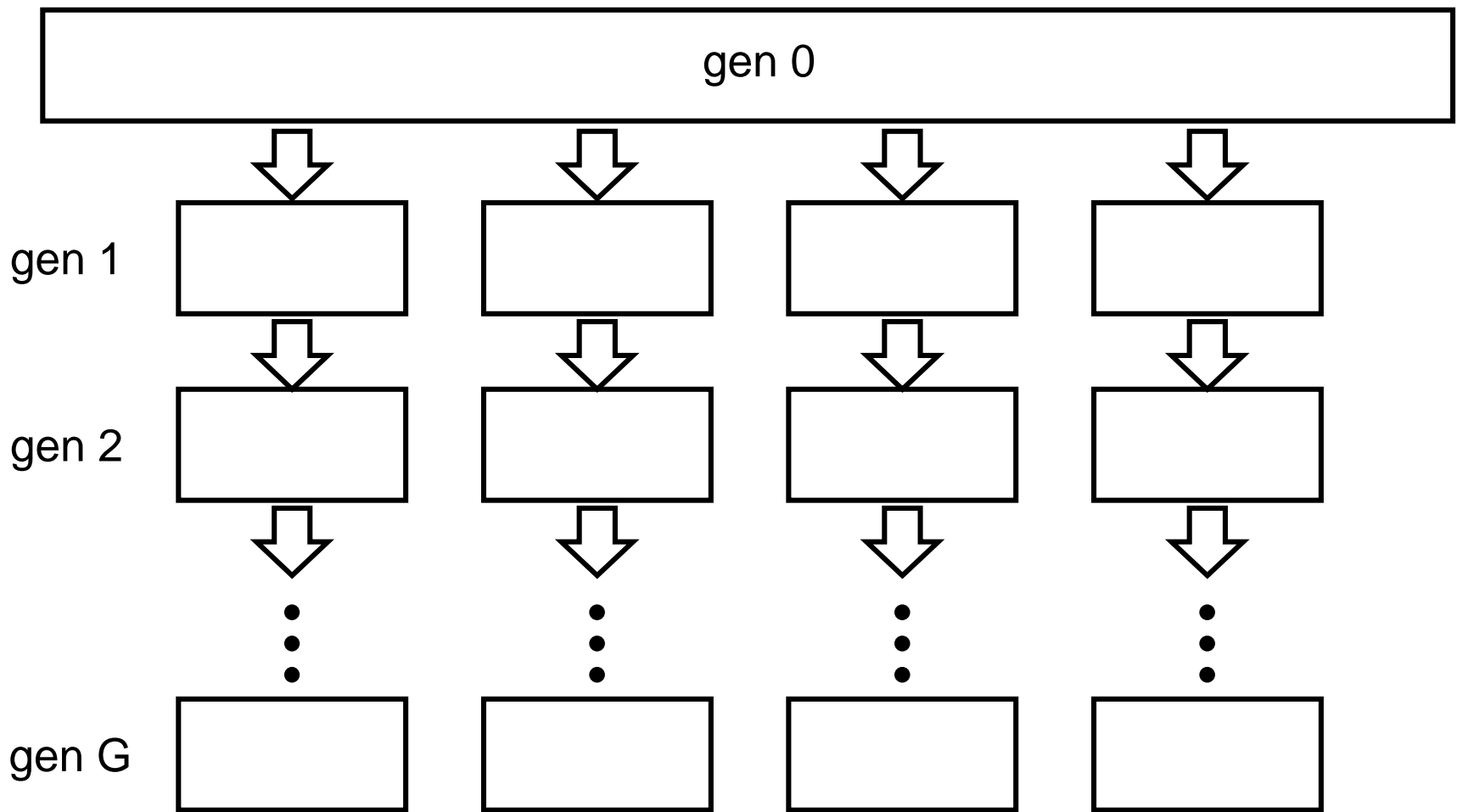

Later in the process, genetic variation will start to be lost within the individual subpopulations. Which alleles become rarer in each subpopulation is random. Variation in p gets larger.

Another way to interpret F_{ST}

- If there is random mating (or close to it) in the subpopulations, we expect to find H-W genotype frequencies within the subpopulations.

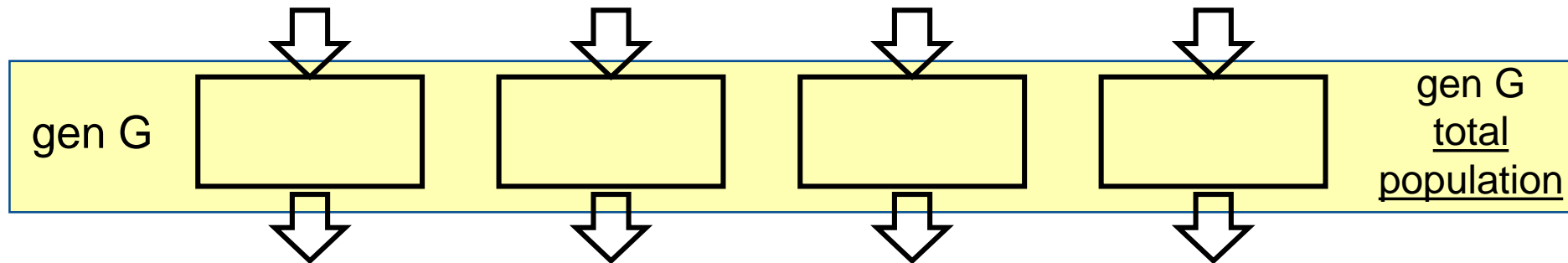

- But, alleles are being fixed and lost within these subpopulations, so allele frequencies are going to their extremes.

H-W genotype frequencies

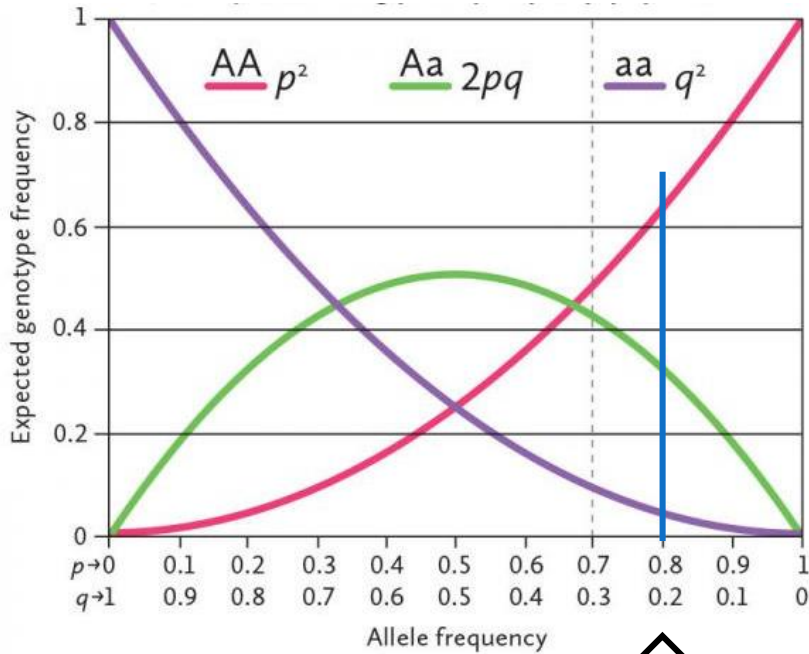

p in one sub-pop might be here ...

A is common in this sub-pop, so **AA** is also common.

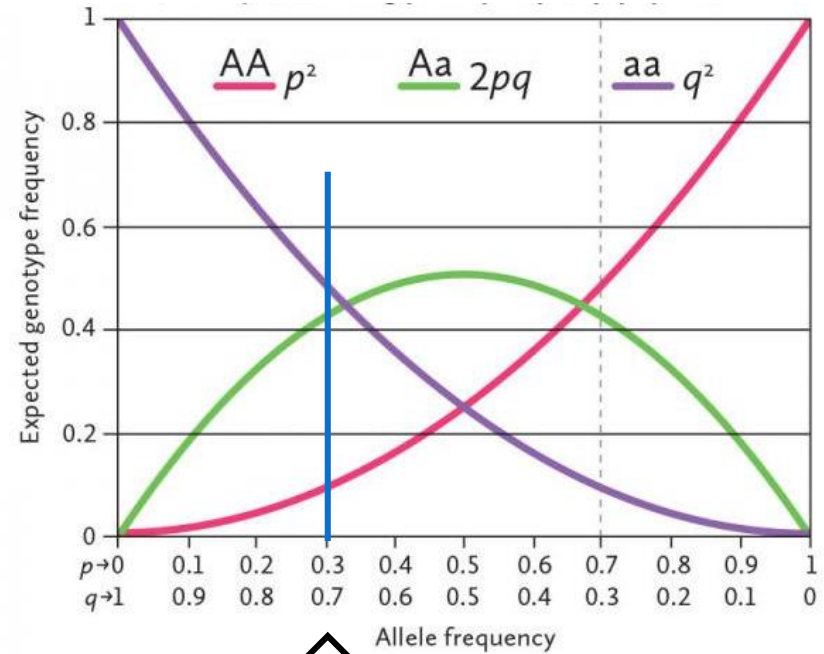

... and in another one p might be here.

A is rarer in this sub-pop, so **AA** is also rarer.

(p was highly similar in both sub-populations at the time of fragmentation)

F_{ST}

- What does the heterozygosity/
homozygosity of the total population
look like?

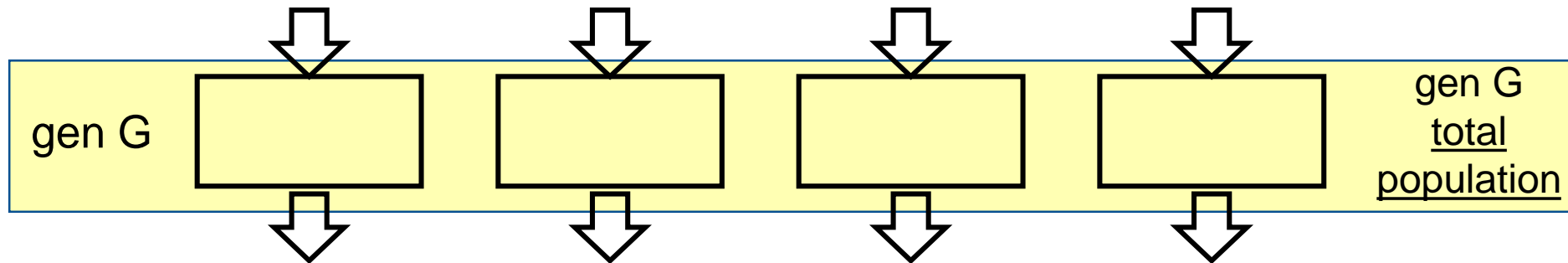

Heterozygosity in the total pop

- Consider a locus with two alleles, A and a .
 - Let's assume a copy of A and a copy of a cannot be IBD.
- So, heterozygous genotypes cannot contain alleles that are IBD.
- What's the frequency of the Aa genotype in the total population?

Heterozygosity in the total pop

- $P_{Aa} = \Pr(\text{chose two alleles from the population that are not IBD}) \times \Pr(\text{one of them is an A allele}) \times \Pr(\text{one of them is an a allele})$

- $P_{Aa} = (1 - F) 2p_{\text{tot}}q_{\text{tot}}$

$F = \text{Fixation index} = \Pr(\text{two randomly chosen alleles from a population are IBD})$

Homozygous frequencies

- $P_{AA} = \Pr(\text{chose two alleles not IBD}) \times \Pr(\text{both of them are } A) + \Pr(\text{chose two alleles that are IBD}) \Pr(\text{they are an } A \text{ allele})$
- $P_{AA} = (1 - F) p_{\text{tot}}^2 + F p_{\text{tot}}$
- $P_{AA} = p_{\text{tot}}^2 + F p_{\text{tot}} q_{\text{tot}}$

In the total population

- $P_{AA} = p_{\text{tot}}^2 + F p_{\text{tot}} q_{\text{tot}}$
- $P_{Aa} = 2p_{\text{tot}} q_{\text{tot}} - F 2p_{\text{tot}} q_{\text{tot}}$
- $P_{aa} = q_{\text{tot}}^2 + F p_{\text{tot}} q_{\text{tot}}$

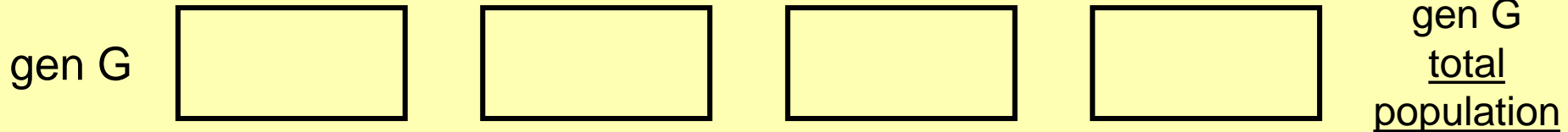

In the total population

- $P_{AA} = p_{\text{tot}}^2 + F p_{\text{tot}} q_{\text{tot}}$

- $P_{Aa} = 2p_{\text{tot}} q_{\text{tot}} - F 2p_{\text{tot}} q_{\text{tot}}$

- $P_{aa} = q_{\text{tot}}^2 + F p_{\text{tot}} q_{\text{tot}}$

H-W
genotype
frequencies

In the total population

- $P_{AA} = p_{\text{tot}}^2$

$$+ F p_{\text{tot}} q_{\text{tot}}$$

- $P_{Aa} = 2p_{\text{tot}}q_{\text{tot}}$

$$- F 2p_{\text{tot}}q_{\text{tot}}$$

- $P_{aa} = q_{\text{tot}}^2$

$$+ F p_{\text{tot}} q_{\text{tot}}$$

degree of
departure from
H-W genotype
frequencies

Interpreting F_{ST}

- When considering a subdivided population, the Fixation index for the total population *is* Wright's F_{ST}
- Using the heterozygosity of the total population:

$$P_{Aa} = 2pq - F_{ST} 2pq$$

$$F_{ST} = \frac{2pq - P_{Aa}}{2pq}$$

(all frequencies are for the total population, this just makes it easier to read)

Interpreting F_{ST}

- $$F_{ST} = \frac{2pq - P_{Aa}}{2pq}$$

(all frequencies are for the total population)

- $2pq$ is the heterozygosity expected if there is random mating across the total population (no fragmentation).
- P_{Aa} is the actual heterozygosity of the total population.

Wright's F statistics

- Subscripts indicate the level of the population structure from which alleles are being drawn.
- F_{ST} (the most commonly used)
 - “ST” – IBD of alleles w/in Subpopulations with respect to the Total population.
- F_{IT}
 - “IT” – alleles w/in Individuals wrt the Total population.
- F_{IS}
 - “IS” – alleles w/in Individuals wrt the Subpopulation.

F_{IT}

- This is an inbreeding coefficient.
- $F_{IT} = \Pr$ (two alleles within an individual are IBD wrt the total population)
 - Sample an individual from the total population, examine the two alleles that individual carries at a locus.
 - Relevant allele frequencies are p_{tot} , q_{tot} .
- If there is random mating within subpopulations, $F_{IT} = F_{ST}$.
 - (under random mating it is equivalent to sample two alleles from a subpopulation or two alleles within an individual in a subpop)

F_{IS}

- This is an inbreeding coefficient.
- $F_{IS} = \Pr$ (two alleles within an individual are IBD wrt the subpopulation)
 - Sample an individual from one subpopulation, examine the two alleles that individual carries at a locus.
 - Relevant allele freqs are $p_{\text{subpop}(i)}$, $q_{\text{subpop}(i)}$.
- If there is random mating within subpopulations, $F_{IS} = 0$.
 - IBD is only considered wrt the previous generation, not further back in time.

Other measures (examples)

- G_{ST}
 - Extension of Wright's F Statistics theory to multiple alleles
 - e.g. microsatellites
- Φ_{ST}
 - Equation structurally similar to F_{ST} , but using nucleotide diversity measures in place of heterozygosity measures.